

BIG LOTS

ASSEMBLY INSTRUCTIONS

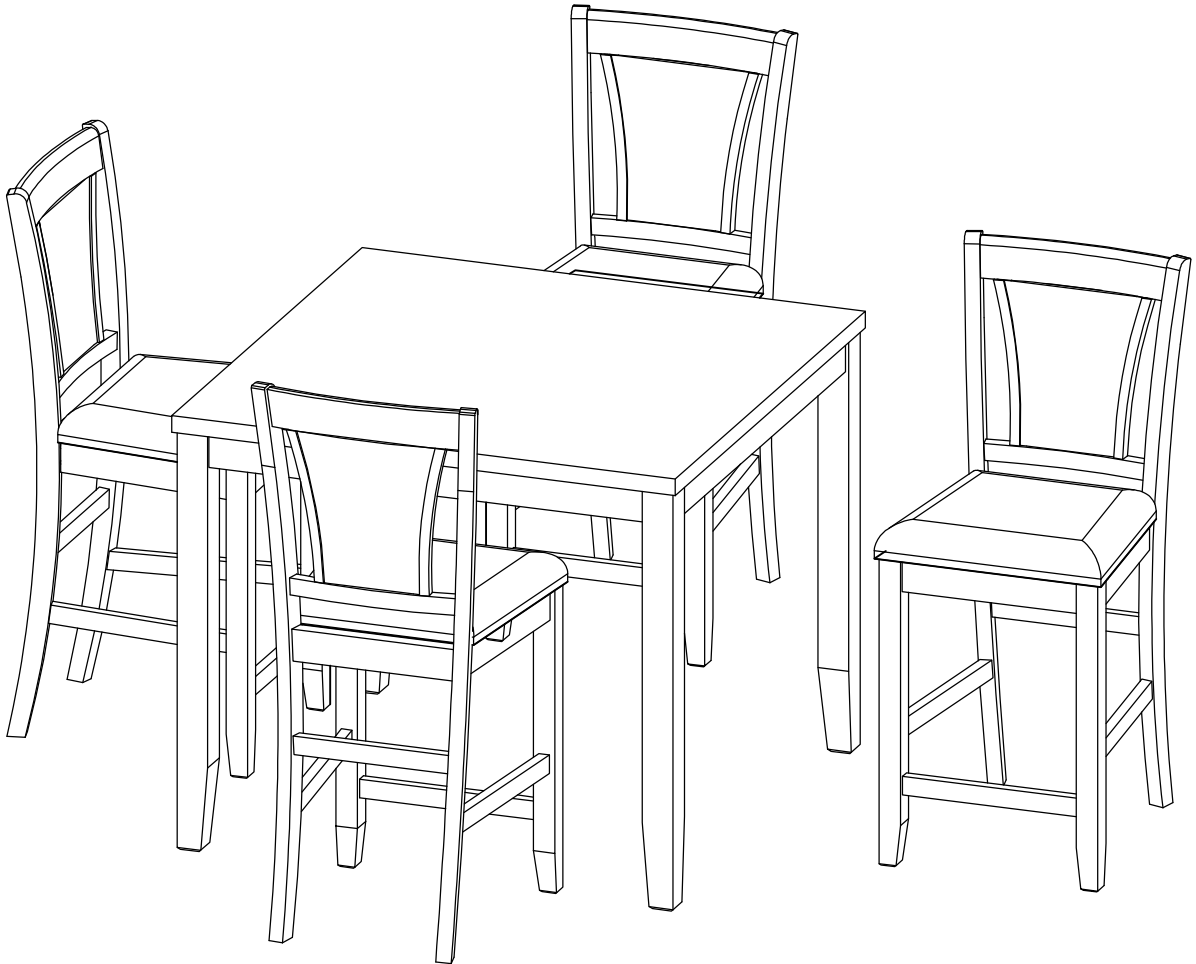

HARLOW 5 PCS PUB SET

ITEM NO. 15160-5PK

SKU NO. 810321490

Big Lots Customer Care

Phone # : 1-866-BIGLOTS(1-866-244-5687)

Email Add : Talk2Us@BigLots.com

'For spare screw and bolts, please contact big lots customer care'

GENERAL INFORMATION, TIPS & TRICKS

1. Please read the assembly instructions prior to assembling this product.
2. To avoid damages, assemble this product on a non-abrasive surface such as carpet.
3. Make sure all bolts and nuts are tightly fastened before the product is used.
4. Not for commercial use.
5. Care: Wipe with a damp cloth. Use furniture polish or lemon oil on the wood as needed. Avoid prolonged exposure to moisture.

Please make sure you have all parts before beginning assembly. Please wait until all steps are completed before tightening bolts. We recommend two people to assemble.



A phillips head screwdriver is necessary for assembly.

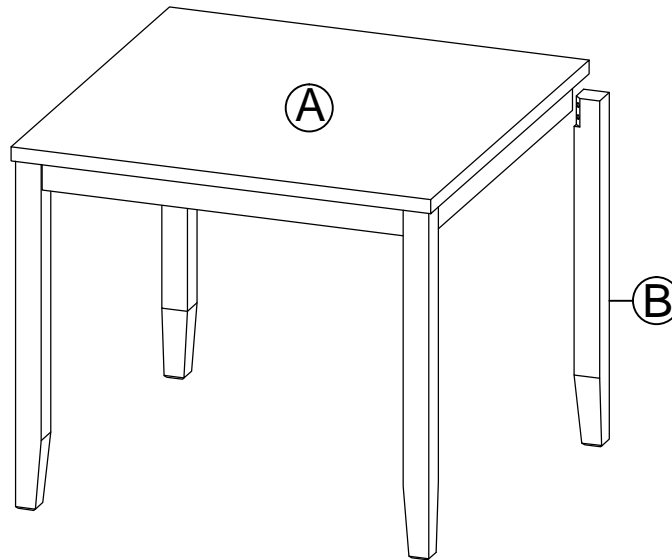

Do not put hot pot or objects which are more than 80 degrees Fahrenheit directly on the table surface.

PUB TABLE PART LIST





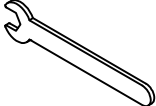

- A. TABLE TOP 1 PC
- B. TABLE LEG 4 PCS

PUB TABLE HARDWARE LIST

1. FLAT WASHER	2. SPRING WASHER	3. BOLT	4. OPEN WRENCH
			
SIZE: 5/16" DIA	SIZE: 5/16" DIA	SIZE: 5/16" x 3"	SIZE: #12mm
QTY: 8 PCS	QTY: 8 PCS	QTY: 8 PCS	QTY: 1 PC

PUB TABLE ASSEMBLY INSTRUCTIONS

DIAGRAM #1

REQUIRED HARDWARE IN THIS STEP			
NO	DESCRIPTION	SKETCH	QTY
1	FLAT WASHER		8 PCS
2	SPRING WASHER		8 PCS
3	BOLT		8 PCS
4	OPEN WRENCH		1 PC

1. Place table top (A) upside down on a non-abrasive surface such as carpet (underside of tabletop should be facing up).

2. Attach the legs (B) to the apron of table top (A) using 8 flat washers (1), 8 spring washers (2), and 8 bolts (3) as shown.

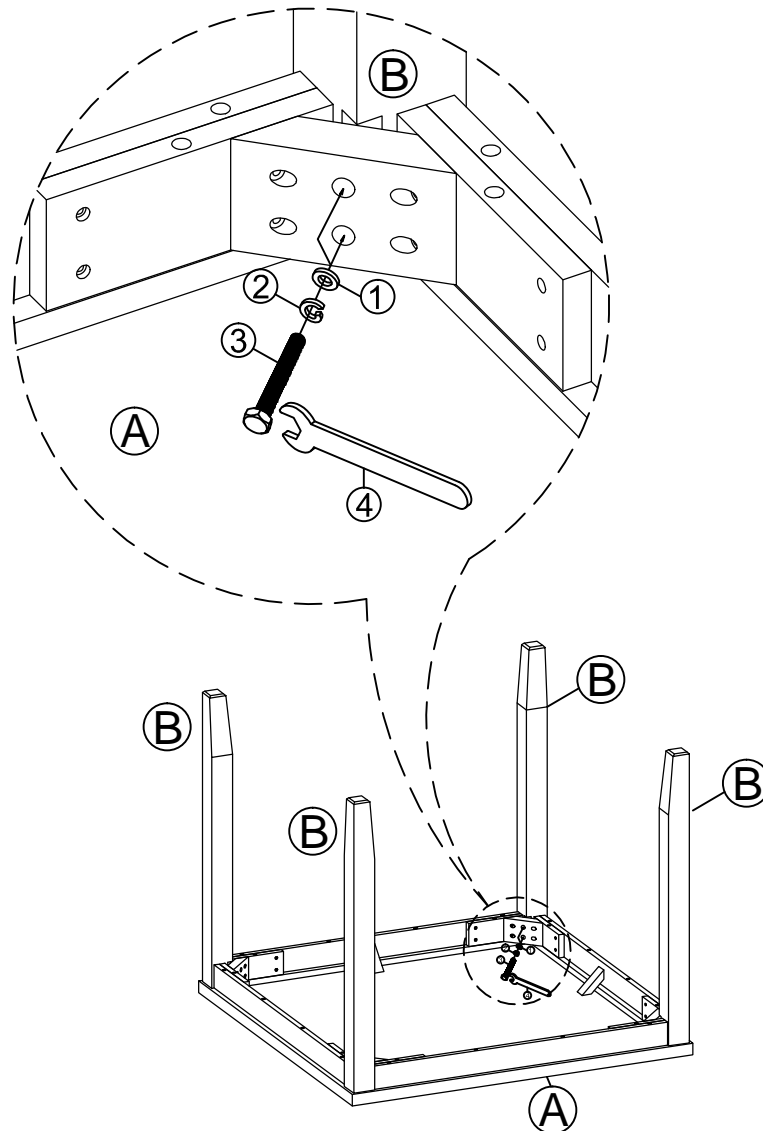

PUB TABLE ASSEMBLY INSTRUCTIONS

DIAGRAM #2

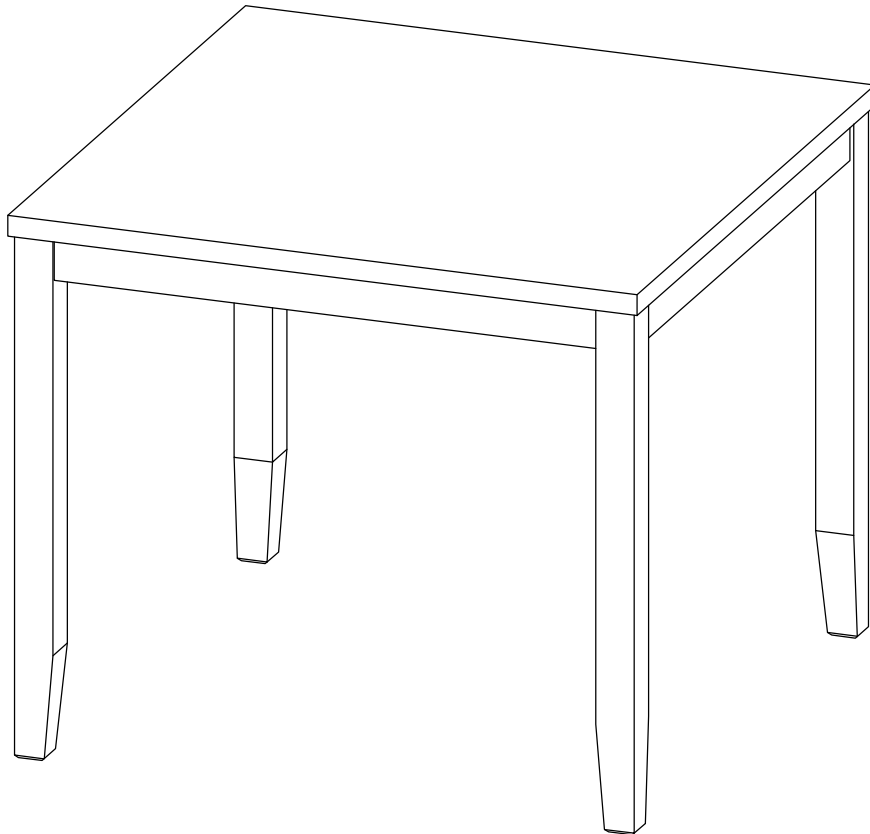

3. With assistance, carefully turn the table upright. Ensure the table is level and tighten all bolts (3) using the open wrench (4).





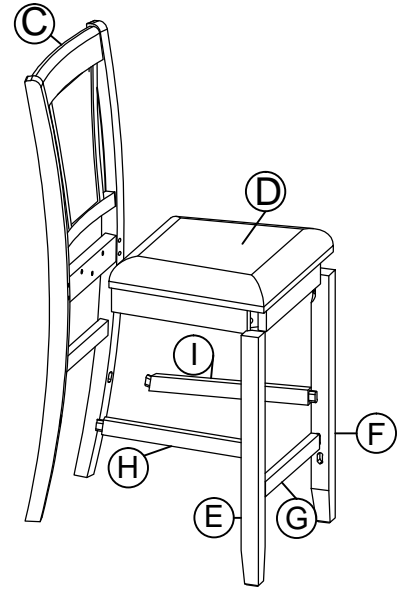

The Table is now ready for use

BAR STOOL PART LIST

- C. CHAIR BACK 4 PCS
- D. SEAT FRAME 4 PCS
- E. LEFT FRONT LEG 4 PCS
- F. RIGHT FRONT LEG 4 PCS
- G. FRONT STRETCHER 4 PCS
- H. LEFT STRETCHER 4 PCS
- I. RIGHT STRETCHER 4 PCS



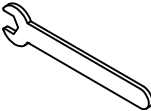



BAR STOOL HARDWARE LIST

1. FLAT WASHER	2. SPRING WASHER	3. BOLT	4. BOLT
			
SIZE: 5/16" DIA	SIZE: 5/16" DIA	SIZE: 1/4" x 1-3/4"L	SIZE: 1/4" x 2-5/9"L
QTY: 44 PCS	QTY: 44 PCS	QTY: 12 PCS	QTY: 16 PCS
5. BOLT	6. OPEN WRENCH	7. WOOD SCREW	
			
SIZE: 1/4" x 3-3/8"L	SIZE: #12mm	SIZE: 4 x 50	
QTY: 16 PCS	QTY: 1 PC	QTY: 24 PCS	

BAR TOOL ASSEMBLY INTRUCTIONS

DIAGRAM #3



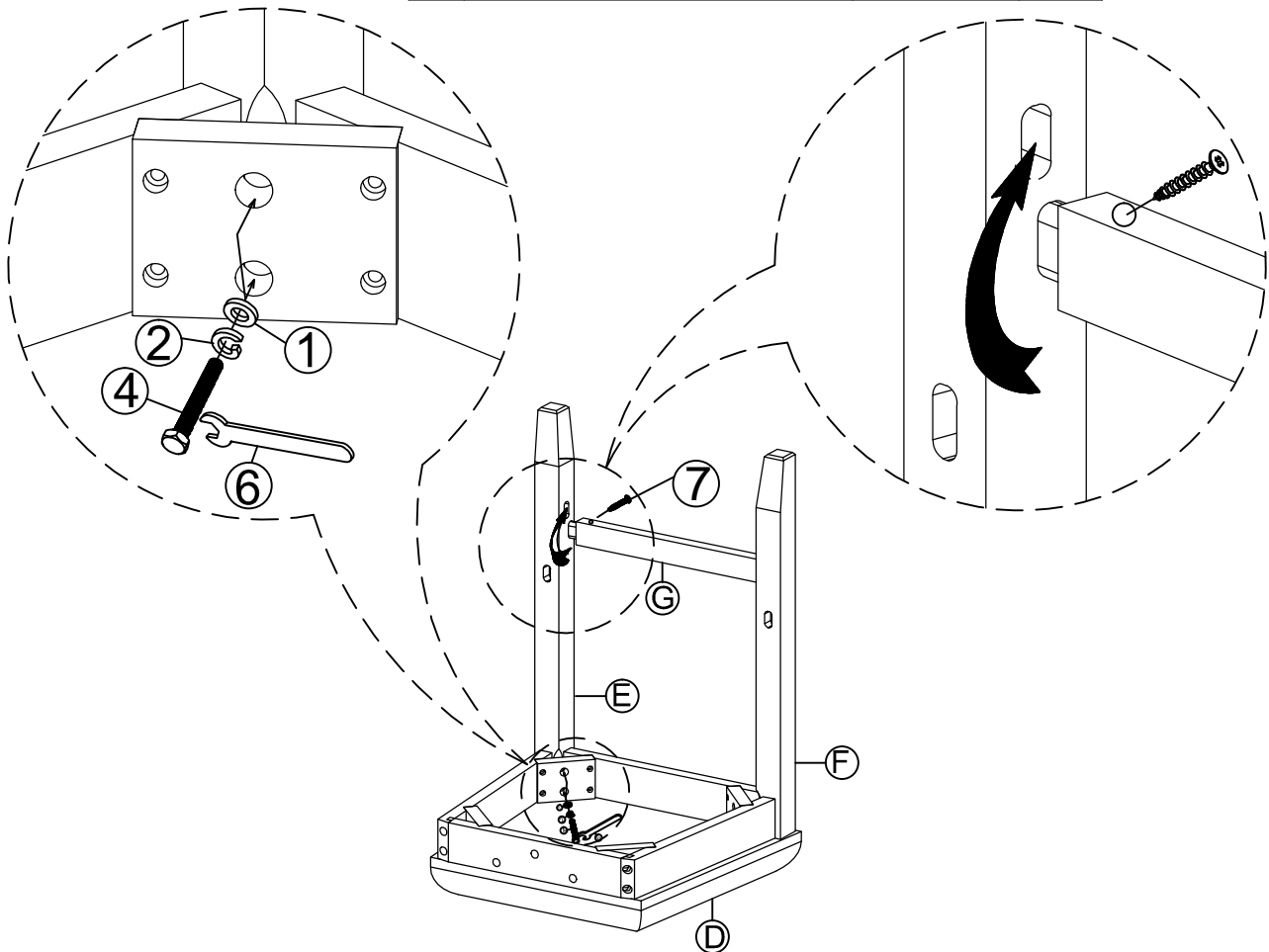



REQUIRED HARDWARE IN THIS STEP			
NO	DESCRIPTION	SKETCH	QTY
1	FLAT WASHER		4 PCS
2	SPRING WASHER		4 PCS
4	BOLT		4 PCS
6	OPEN WRENCH		1 PC
7	WOOD SCREW		2 PCS



1. Attach Left Front Leg (E) and Right Front Leg (F) to Seat Frame (D) using 4 Flat Washers (1), 4 Spring Washers (2) and 4 Bolt (4) as shown. Do not fully tighten all bolts at this time. Insert the Front Stretcher (G) into the holes of the Left Front Leg (E) and Right Front Legs (F) as shown and attach using 2 Wood Screws (7). Fully tighten the screws.

BAR TOOL ASSEMBLY INTRUCTIONS

DIAGRAM #4

REQUIRED HARDWARE IN THIS STEP			
NO	DESCRIPTION	SKETCH	QTY
1	FLAT WASHER		7 PCS
2	SPRING WASHER		7 PCS
3	BOLT		3 PCS
5	BOLT		4 PCS
6	OPEN WRENCH		1 PC
7	WOOD SCREW		4 PCS

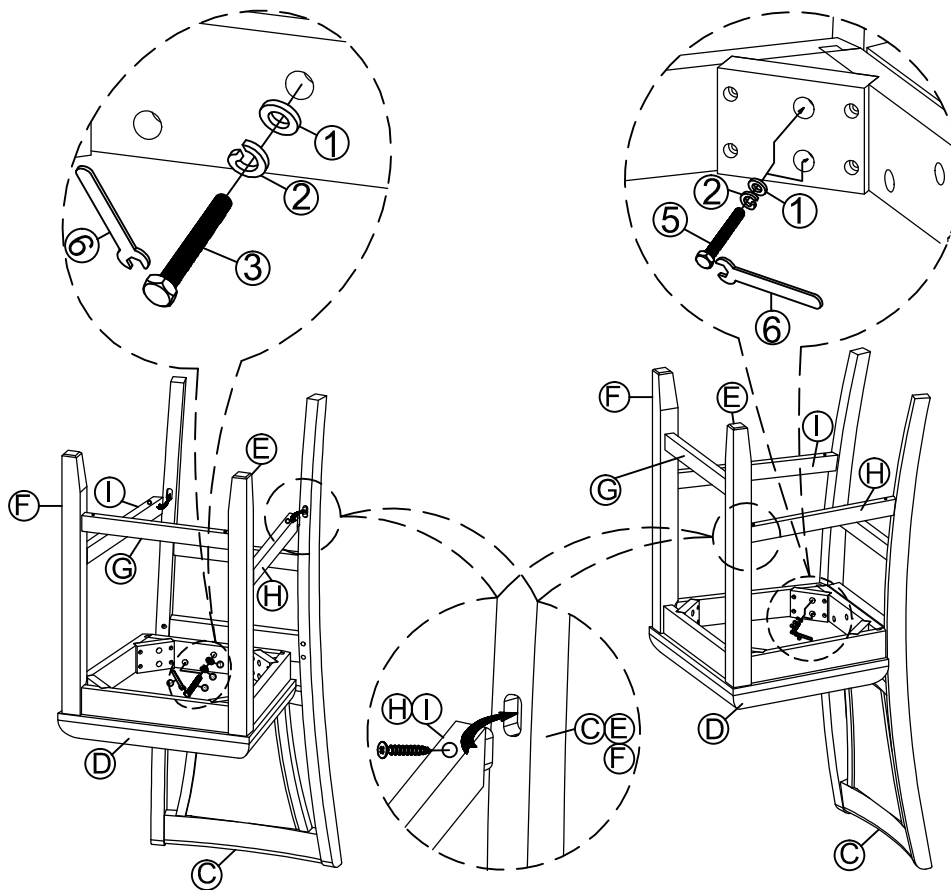

2. Attach Seat Frame (D) to Chair Back (C) using 3 Bolts (3), 4 Bolts (5), 7 Spring Washers (2) and 7 Flat Washers (1) as shown. Do not fully tighten bolts. Insert the end of Left Stretcher (H) into the holes in Left Front Leg (E) and Chair Back (C). Secure using 2 Wood Screw (7). Fully tighten screws. Insert the end of Right Stretcher (G) into the holes in Right Front Leg (F) and Chair Back (C). Secure using 2 Wood Screw (7). Fully tighten screws.

3. With assistance, carefully turn the assembled chair upright. Make sure the assembled chair is level and square tighten all bolts (3 & 5) with Open Wrench (6)

BAR TOOL ASSEMBLY INTRUCTIONS

DIAGRAM #5

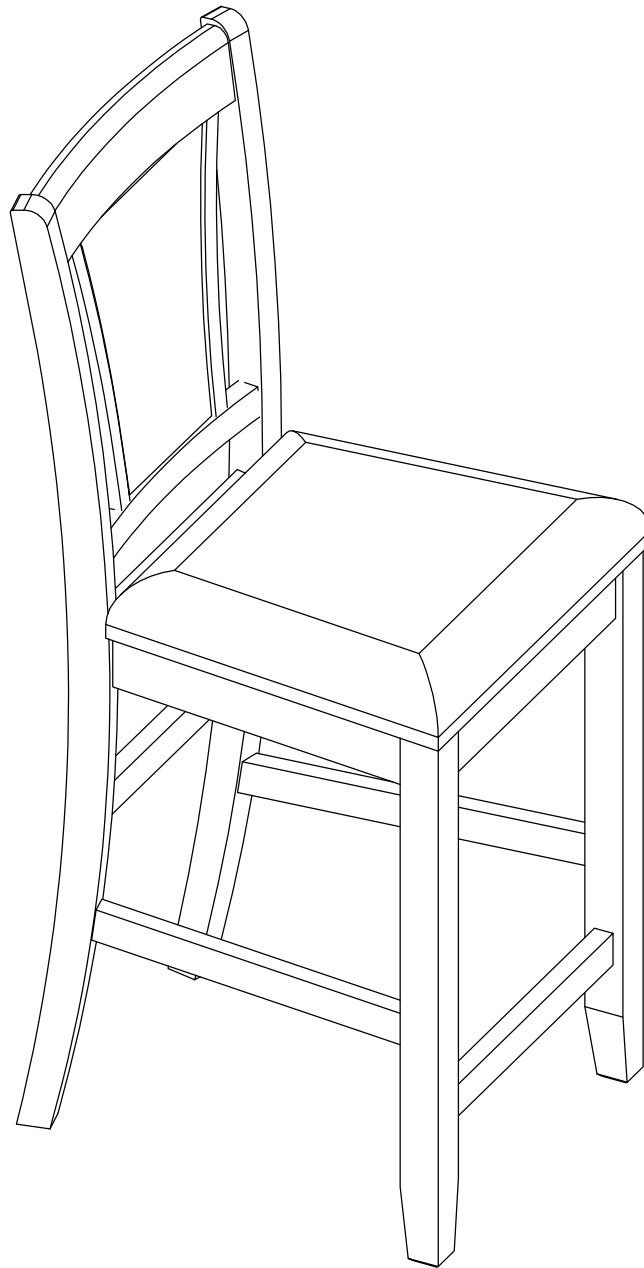

The bar stool is now ready for use.

6. Repeat diagram #3 to #5 to assemble the other chairs.