

Assembly Instruction

Item No.: BL2017004

SKU No.: 810382193

Description: Gark Grey Velvet Cutout Bed

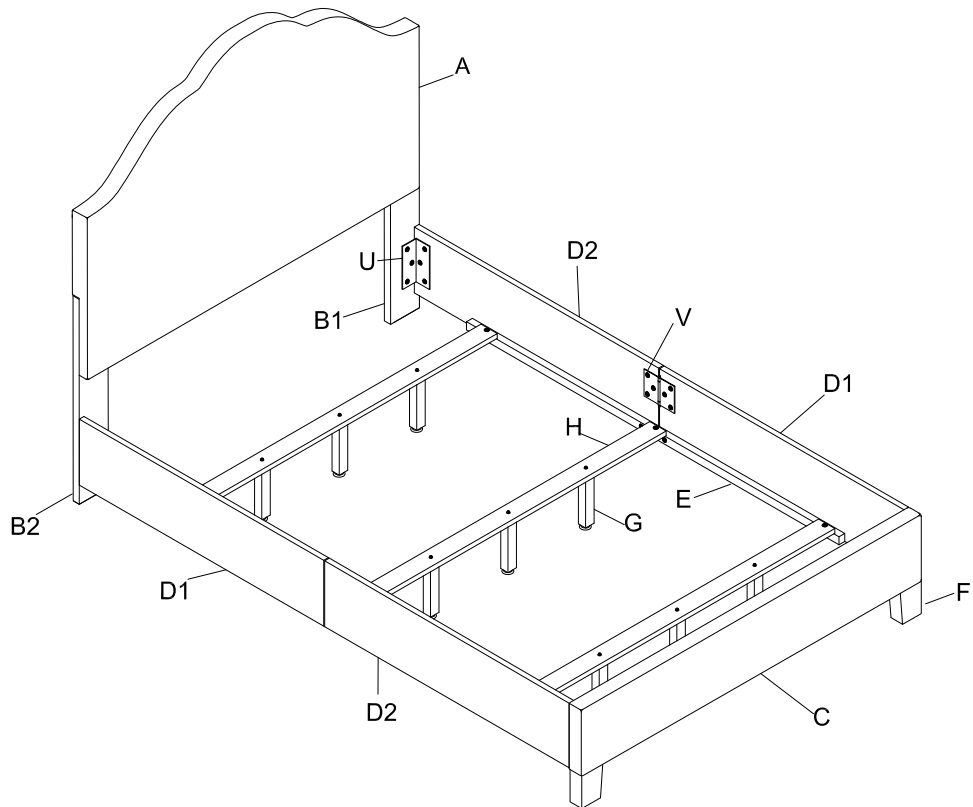

PARTS LIST:

PARTS LIST:

No.	Description	Sketch	Quantity	No.	Description	Sketch	Quantity
A	Headboard		1 PC	D2	Rail		2 PCS
B1	Headboard Leg		1 PC	E	Tube		2 PCS
B2	Headboard Leg		1 PC	F	Footboard Leg		2 PCS
C	Footboard		1 PC	G	Support leg		9 PCS
D1	Rail		2 PCS	H	Slat		3 PCS



For spare metal parts, please contact Big Lots Customer Care

Tel: 1-866-244-5687

E-Mail: talk2us@biglots.com

HARDWARE LIST:

HARDWARE LIST:

No.	Description	Sketch	Quantity	No.	Description	Sketch	Quantity
J	Allen Bolt (5/16"*2-1/4")		12 PCS	O	Flat Washer		64 PCS
K	Allen Bolt (5/16"*1")		36 PCS	P	Allen Key		1 PCS
L	Allen Bolt (5/16"*1-1/2")		14 PCS	Q	Wood Dowel		2 PCS
M	Allen Bolt (5/16"*3-1/4")		2 PCS	U	Angle Iron		4 PCS
N	Spring Washer		64 PCS	V	Hinge		2PCS

*** Please find the parts behind the black cover as below shown.

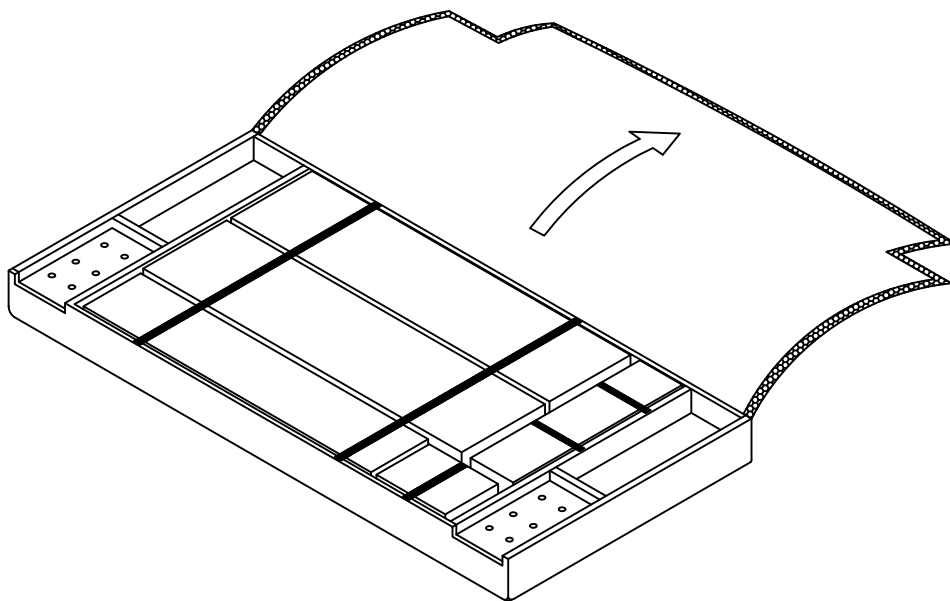

Step 1

- a. Lay the headboard (A) on the floor with the back facing up.
- b. Attach Headboard Leg (B1) and Headboard Leg (B2) to the Headboard (A) with Allen Bolt (J), Spring Washer (N) and Flat Washer (O) using Allen Key (P) as shown.
- c. Ensure the legs are straight and fully tighten all bolts.

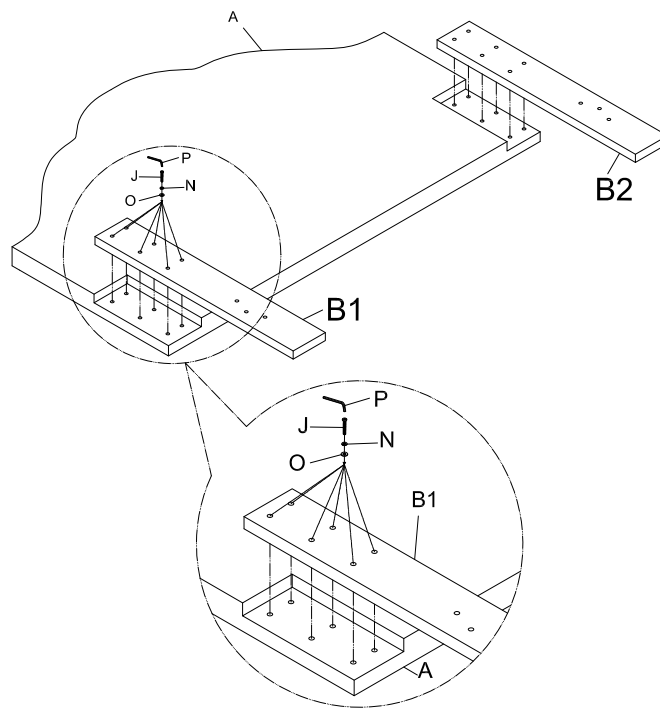

Step 2

- a. Lay the Side Rail (D1) and Side Rail (D2) flat with holes facing up.
- b. Align Hinge (V) with the holes in Side Rail (D1) and Side Rail (D2).
- c. Attach Hinge (V) to Side Rails (D1) and (D2) with Allen Bolt (K), Spring Washer (N) Flat Washer (O) using Allen Key (P).
- d. Fully tighten all bolts.

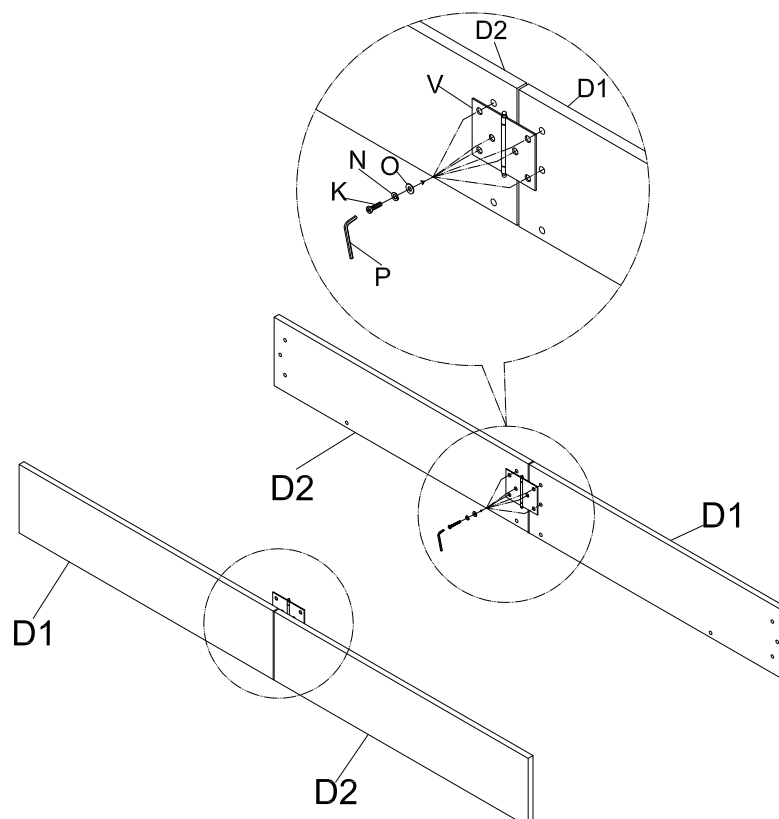

- Step 3**
- Align Tube (E) with the holes in Side Rail (D1) and Side Rail (D2).
 - Attach Tube (E) to Side Rails (D1), (D2) with Allen Bolt (L), Spring Washer (N) and Flat Washer (O) using Allen Key (P) as shown.
 - Fully tighten all bolts.

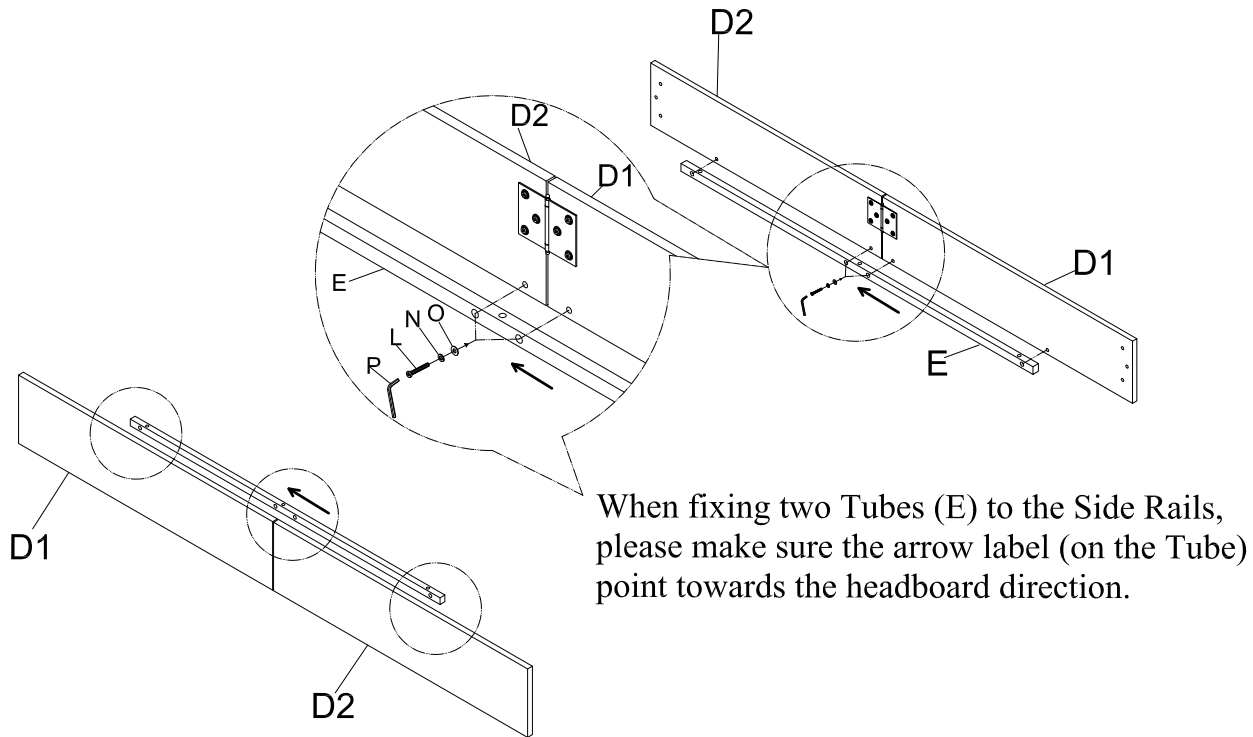

- Step 4**
- Attach the Angle Iron (U) to the assembled Side Rails with Allen Bolt (K), Spring Washer (N) and Flat Washer (O) using Allen Key (P) as shown.
 - Ensure Angle Iron is flush with Side rail end and fully tighten all bolts.

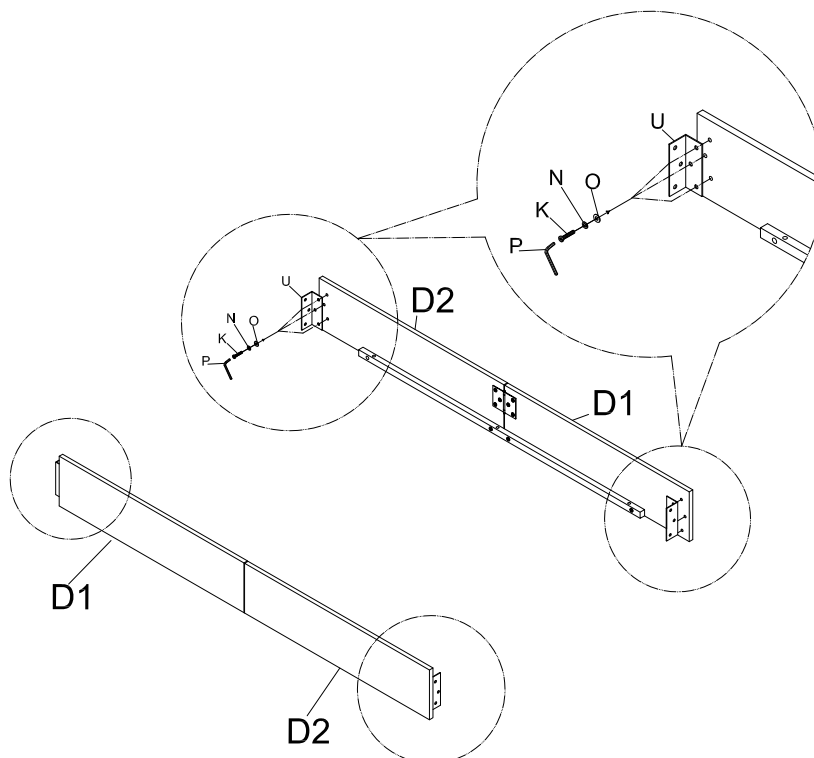

Step 5

- a. Insert Wood Dowel (Q) into the smaller holes of Leg (F) as shown.
- b. Lay the Footboard (C) upside down.
- c. Align the Wood Dowel (Q) in Leg (F) with the inside hole in Footboard (C) and attach with Allen Bolt (M), Spring Washer (N) and Flat Washer (O) using Allen Key (P) as shown.
- d. Fully tighten all bolts.

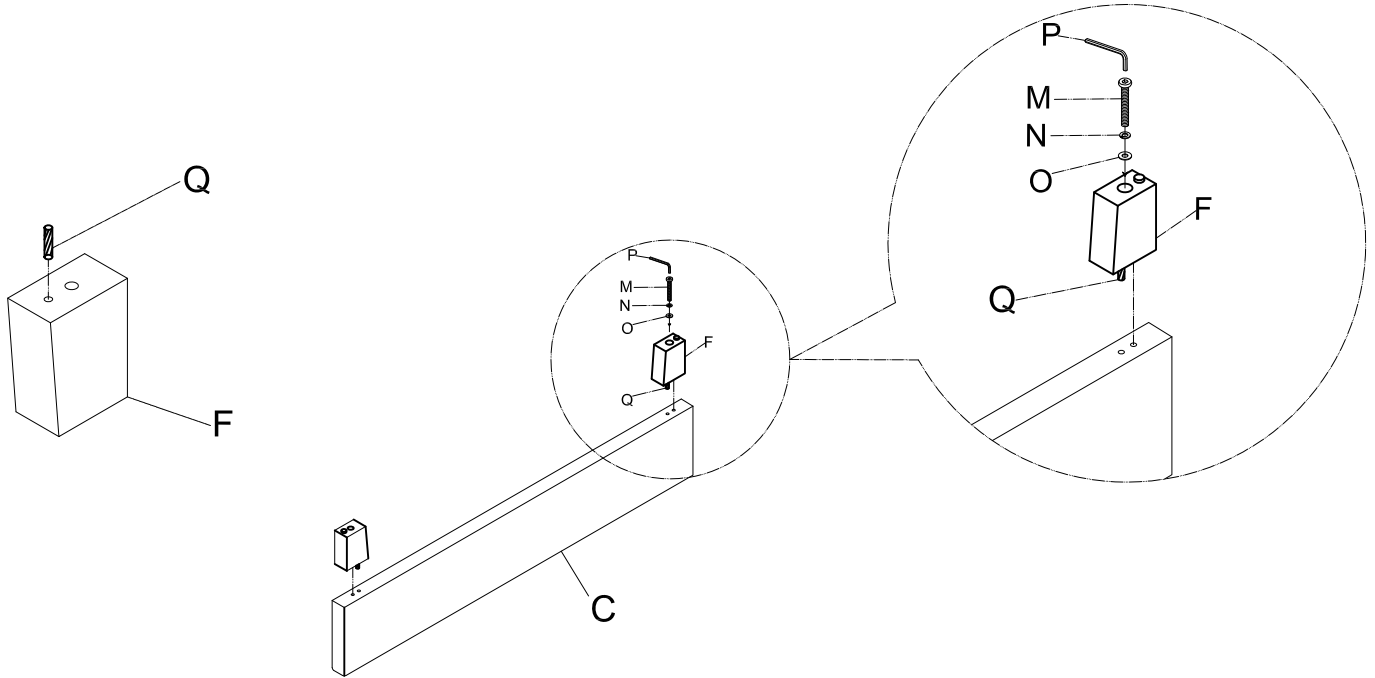

Step 6

- a. With the arrow on Tube (E) pointing the direction of the Headboard, attach the assembled Side Rails to the Footboard (C) with Allen Bolt (K), Spring Washer (N) and Flat Washer (O) using Allen Key (P) as shown.
- b. Do not fully tighten Allen Bolts at this time.

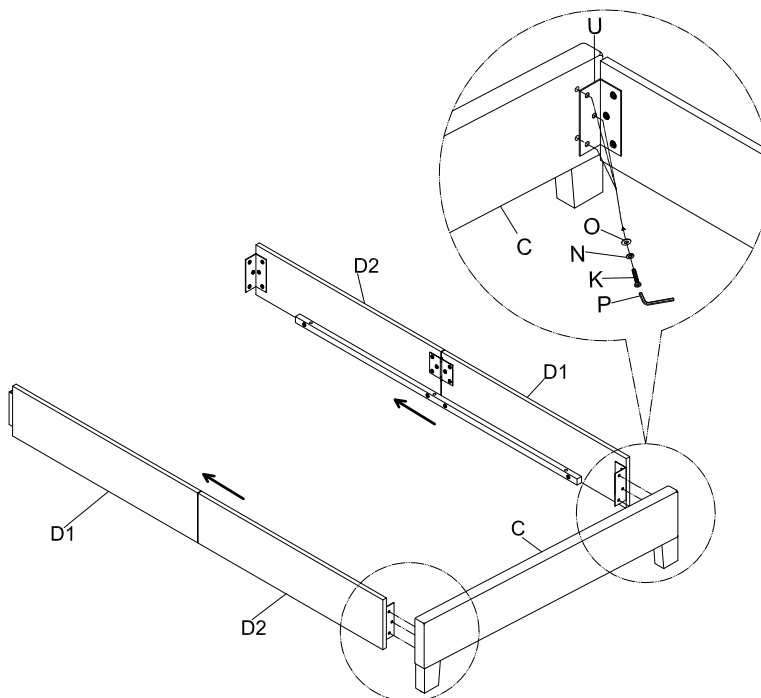

Step 7

- a. Attach the assembled Side Rails to the Headboard Leg (B1), Headboard Leg (B2) with Allen Bolt (K), Spring Washer (N) and Flat Washer (O) using Allen Key (P) as shown.
- b. Do not fully tighten Allen Bolts at this time.

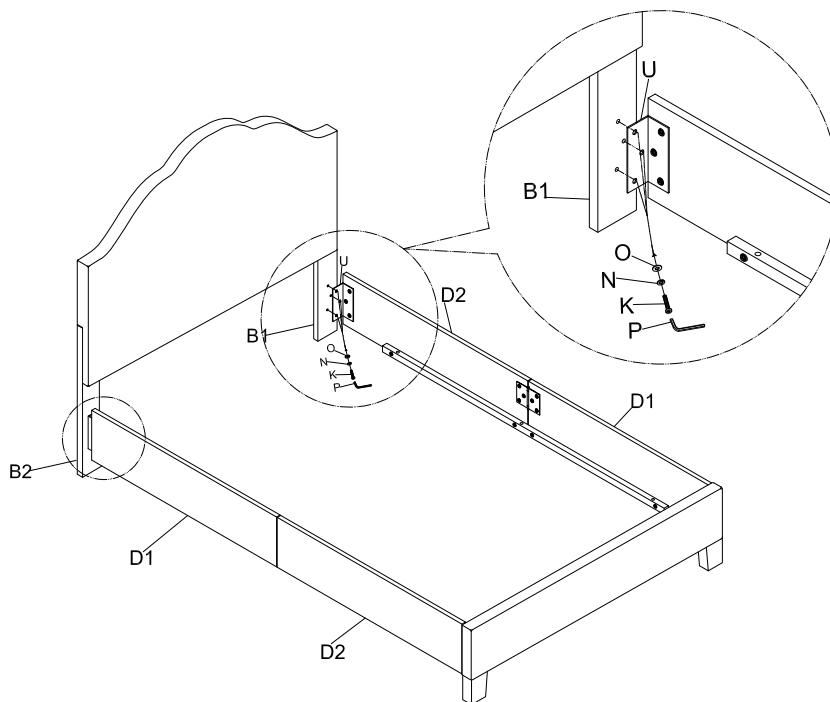

Step 8

- a. Insert the Support Leg (G) into Slat (H) and fully tighten.

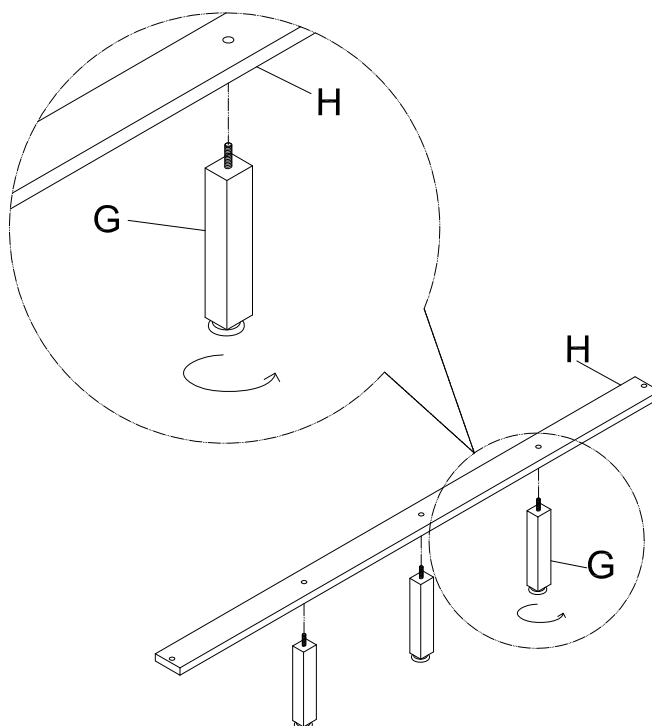

Step 9

- a. Attach Slat (H) to Tube (E) with Allen Bolt (L), Spring Washer (N) and Flat Washer (O) using Allen Key (P) and fully tighten as shown.
- b. Fully tighten all Allen Bolts from Step 6 and Step 7 at this time.
- c. Adjust the Leg Levelers so all Support Legs reach the floor.

