

ASSEMBLY INSTRUCTION

Step 1

Insert bolts D in the holes, then tighten them to 90%.

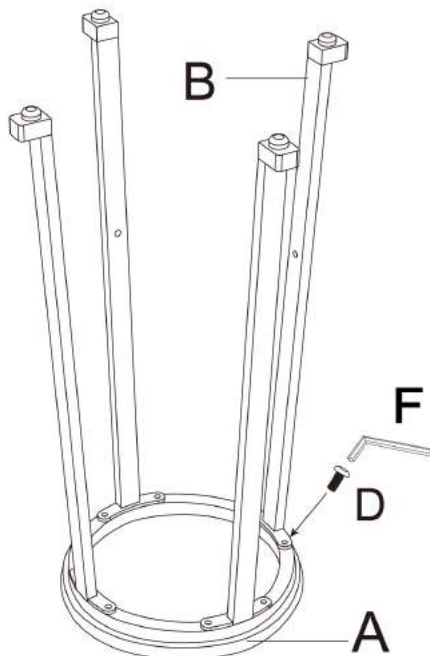

Step 2



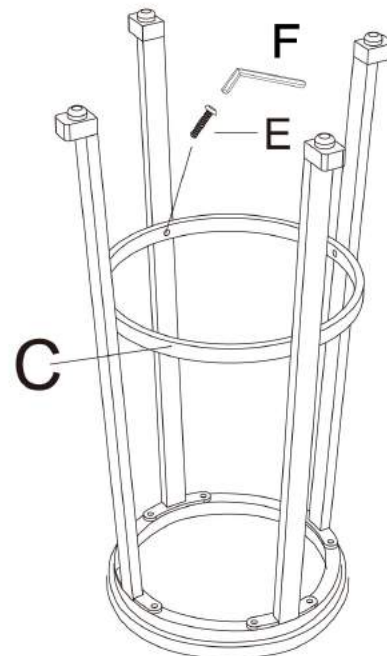



Insert bolts E in the holes, then tighten them to 90%.

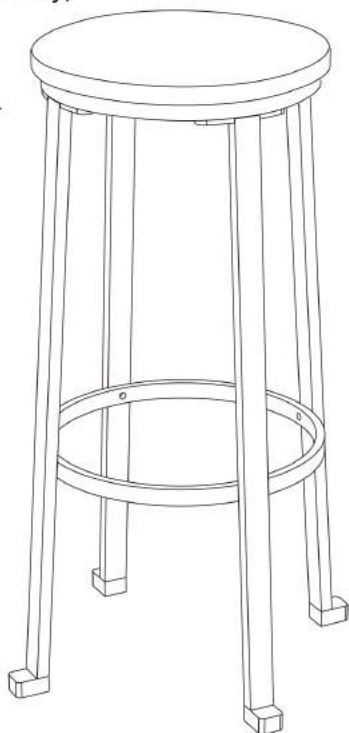

Step 3

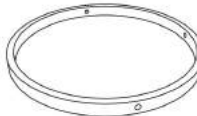
Please tighten all bolts D and E to 100%.
A few days after initial assembly, the product may acclimate to its new environment. Please ensure all bolts are still securely tightened.



HARDWARE LIST	CODE	PARTS	QTY.
	A		1
	B		4
	C		1
	D	 M6 X 16MM	8
	E	 M6 X 20MM	4
F	 ALLEN KEY	1	