

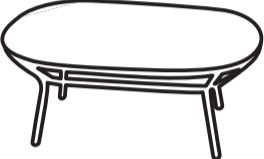
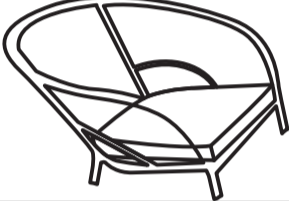
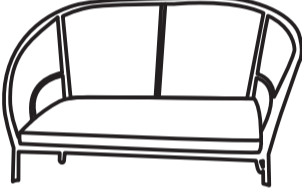

Part List

		1 pc
		2 pcs
		1 pc
A		Long leg 6 pcs
B		Short leg 6 pcs

STOP!
 Missing A Part?
 No Need To Go Back To
 The Store
 The store where you made your purchase
 does not stock parts for this item.
 If you need parts,
 whether they are missing or damaged,
 Call Toll Free:
 TEL: 1-877-998-1697
 FAX: 1-905-754-3898
 Call us between 9:00 AM and 5:00 PM
 Eastern Time Monday through Friday
 For further assistance,
 please visit us at
 service@nanshanint.com

Step:

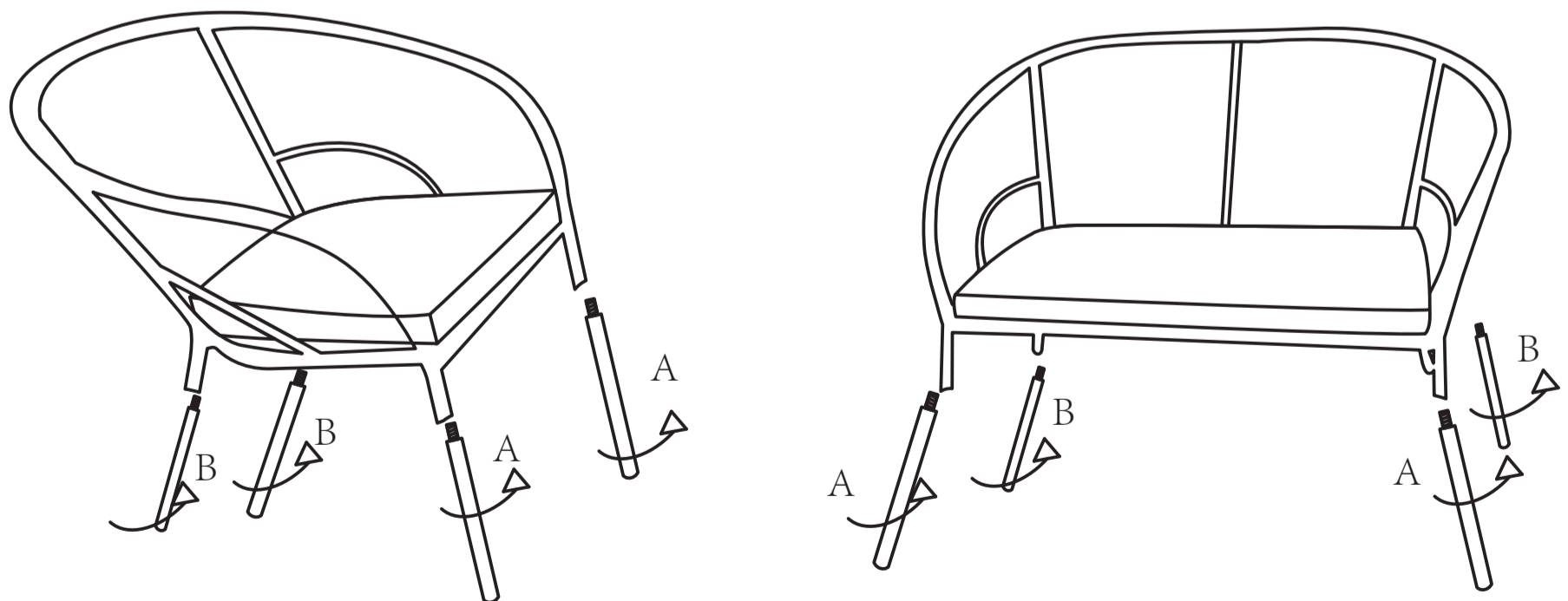

WARNING: EACH DOUBLE SEAT SOFA IS RATED TO SUPPORT 450 LBS,
 EACH SINGLE SEAT CHAIR IS RATED TO SUPPORT 225LBS,
 FAILURE TO FOLLOW WEIGHT LIMIT GUIDELINE MAY RESULT IN DAMAGE OR INJURY.