





# ASSEMBLY INSTRUCTIONS

ATTENTION: THIS PRODUCT IS NOT FOR COMMERCIAL USE  
INTENDED FOR RESIDENTIAL USE ONLY.

## KVA9195

### PARTS LIST

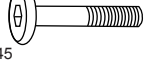
PART NO.	MATERIAL CODE	PART	Q'TY
1	KVA9195-CS11-2	 SEAT ASSEMBLY	1
2	KVA9195-CS04-1	 LEG	1

3	17C33D0716001YX	 BOLT M6*45	4
4	17FD05040301-YX	 WASHER d6.5*D13*1.0	4
5	61K9195C00001BA	 SEAT CUSHION	1

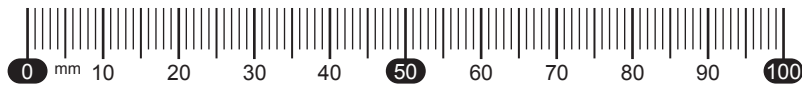
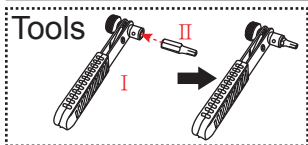

**FIGURE 1**

**PARTS REQUIRED: 1, 2, 3, & 4**

Tighten all bolts by using the supplied Hex key.

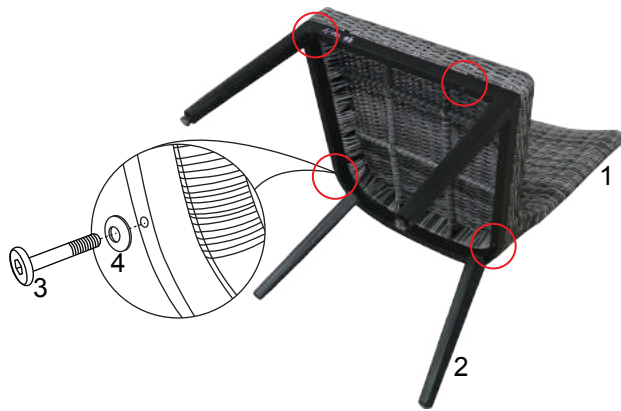

**FIGURE 2**

**PARTS REQUIRED: 5**

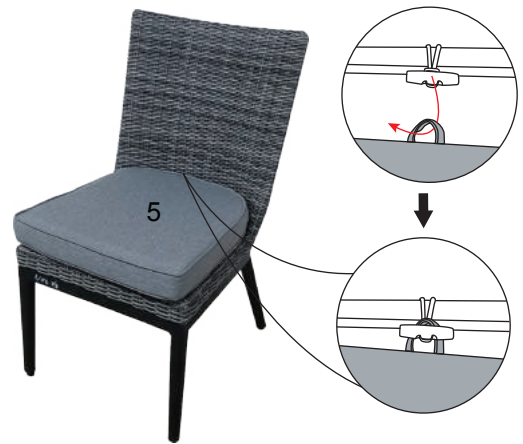

**Attention:**

Make sure that each bolt needed for all steps matches the corresponding figure to ensure proper assembly.

- ⚠ Use the correct bolts as indicated. Do not tighten any of the bolts until the chair is completely assembled.
- ⚠ Do not discard any of the packaging until you have checked that you have all of the parts and fittings required.
- ⚠ Keep children away during assembly. This item contains small parts that can be swallowed by children. Children should always be under direct adult supervision while using this product.
- ⚠ Retain these assembly instructions for future reference.
- ⚠ Quote the following FQC No. when contacting the service center.

SERVICE CENTER TOLL FREE NO.

TEL: 1-888-599-8084

FAX: 1-312-266-4945

## Cleaning and Maintenance

- Wash frame and fabric parts with mild soap and water, rinse thoroughly, and dry completely. Do not use bleach, acid, or other solvents on the frame or fabric parts.
- The cushions may be washed on the surface only by using mild soap and water or a commercial foaming upholstery cleaner if necessary. If washed, rinse well and hang to dry. Do not machine wash or dry.
- We recommend the use of furniture covers when not in use.
- Inspect and tighten all of the bolts and fasteners on a regular basis to ensure the proper performance and safety of your chair.
- In order to prolong the life and beauty of your chair, we recommend that it be stored in a dry and protected area during off season periods.



### READ THESE INSTRUCTIONS COMPLETELY BEFORE STARTING ASSEMBLY

- ★ SEPARATE AND IDENTIFY ALL PARTS, MAKING SURE THAT YOU HAVE ALL OF THE PARTS LISTED.
- ★ IF YOU DO NOT LOCATE ALL OF THE PARTS LISTED, INSPECT THE PACKING MATERIAL FOR SMALL PARTS THAT MAY HAVE BECOME SEPARATED DURING SHIPMENT.
- ★ IF YOU EXPERIENCE ANY DIFFICULTY DURING ASSEMBLY OR IF ANY PARTS ARE MISSING OR DAMAGED, CALL THE HELP LINE AT 1-888-599-8084 BEFORE RETURNING THIS ITEM TO THE STORE.
- ★ PROVIDE THE FOLLOWING INFORMATION WHEN CALLING:  
1-MODEL NUMBER OF THE PRODUCT.  
2-PART NUMBER AND MATERIAL CODE OF THE PART FROM THE PARTS LIST.
- ★ MOST PROBLEMS CAN BE RESOLVED WITHOUT RETURNING THIS PRODUCT TO THE RETAILER.