

# MOBILE LAPTOP STATION – BLACK

ASSEMBLY INSTRUCTIONS

ITEM# BG-102120

SKU# 810562098

Need help? We are here for you!  
[www.biglots.com/help/contact-us](http://www.biglots.com/help/contact-us)

## **GENERAL BEST PRACTICES FOR ASSEMBLY:**

Read all instructions before starting  
Clear a flat covered space to assemble  
We recommend two people for assembly  
Note that hardware required is provided for every step  
Pay attention to orientation  
Letter of the part corresponds to a sticker on the product  
Number of the hardware corresponds to its number in the package  
Helpful hints provided along the way

## **MAINTENANCE:**

Regularly check hardware and tighten if necessary

## **CARE AND CLEANING:**

Clean periodically by wiping the product with a soft clean cloth

DO NOT use abrasive chemicals for cleaning

## **WARNINGS:**

Do not tighten the screws until all of them are in place

DO NOT use power tools

# PARTS LIST

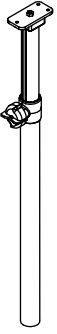

A

x1

Lifting Column

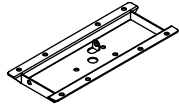

B

x1

Support Panel

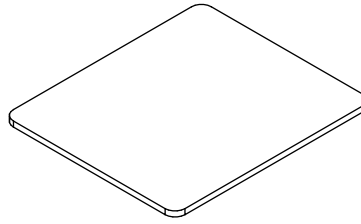

C

x1

Top Panel

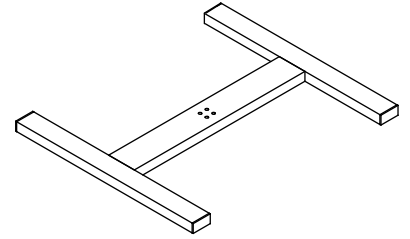

D

x1

Base

# HARDWARE LIST



1

x11

Allen Bolt



2

x4

Allen Bolt



3

x2

Castor Without Brake



4

x2

Castor With Brake



5

x4

Washer



6

x4

Spring Washer

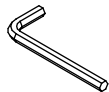

7

x1

Allen Wrench

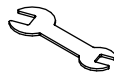

8

x1

Wrench

# HELPFUL HINTS

- Separate parts before starting

# STEP 1

Attach Support Panel (B) to Lifting Column (A) with Allen Bolt (1). Fully tighten.

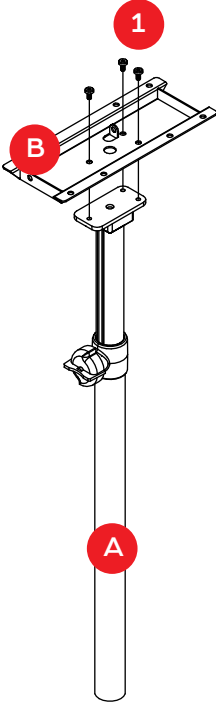

Assembled View:

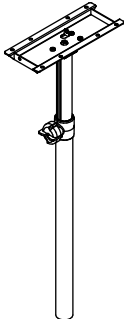

# STEP 2

Attach Support Panel (B) to Top Panel (C) with Allen Bolt (1). Fully tighten.

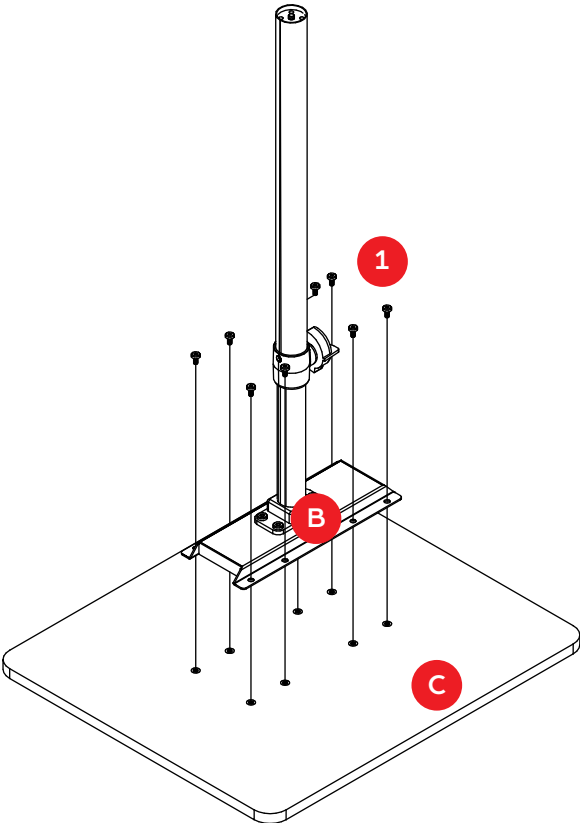

Assembled View:

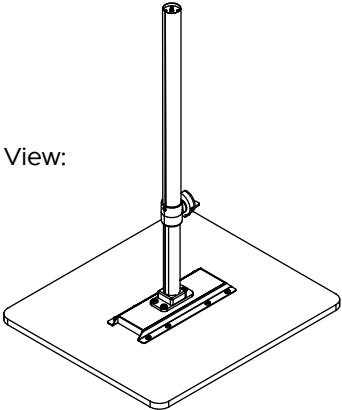

# STEP 3

Attach Base (D) to Lifting Column (A) with Allen Bolt (2). Fully tighten.

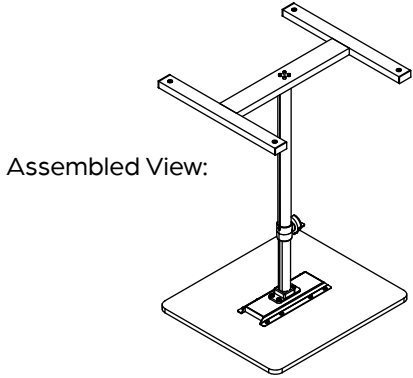
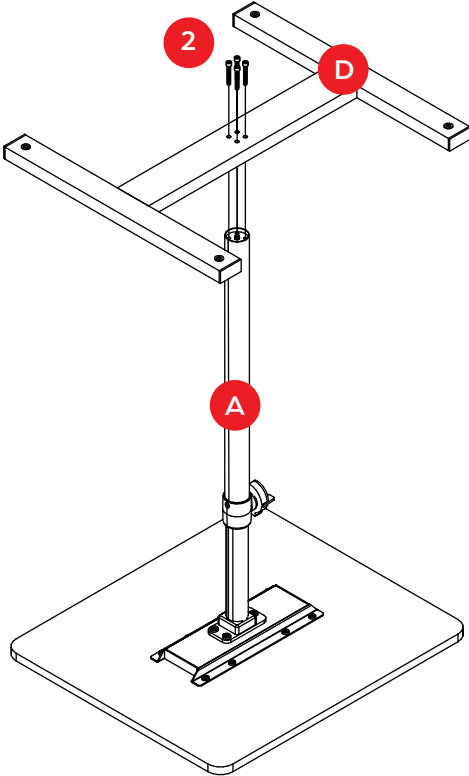

# STEP 4

Insert Castor Without Brake (3) and Castor With Brake (4) into Base (D) with Washer (5) and Spring Washer (6). Fully tighten. Assembly is now complete.

