

 **real**
living™

3 TIER ROLLING CART – GREY

ASSEMBLY INSTRUCTIONS

ITEM# AA-2161
SKU# 810566182

Need help? We are here for you!
www.biglots.com/help/contact-us

GENERAL BEST PRACTICES FOR ASSEMBLY:

Read all instructions before starting
Clear a flat covered space to assemble
We recommend two people for assembly
Note that hardware required is provided for every step
Pay attention to orientation
Letter of the part corresponds to a sticker on the product
Number of the hardware corresponds to its number in the package
Helpful hints provided along the way

MAINTENANCE:

Regularly check hardware and tighten if necessary

CARE AND CLEANING:

Clean periodically by wiping the product with a soft clean cloth

DO NOT use abrasive chemicals for cleaning

WARNINGS:

Do not tighten the screws until all of them are in place

DO NOT use power tools

PARTS LIST

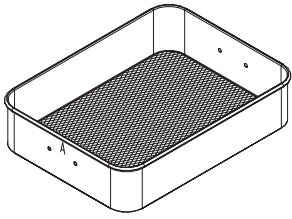

A

x1

Upper Basket

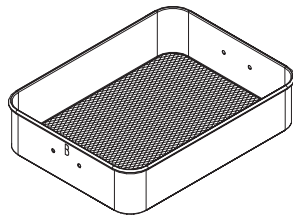

B

x1

Middle Basket

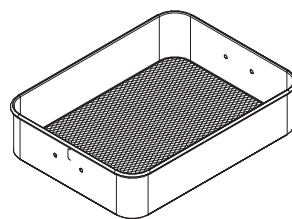

C

x1

Bottom Basket

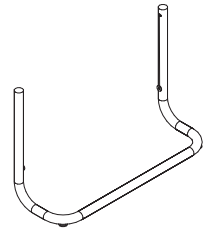

D

x2

Base

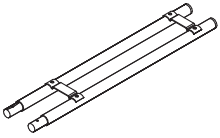

E

x2

Side Frame

HARDWARE LIST



1

x4

Phillips Screw



2

x12

Allen Bolt



3

x4

Nut



4

x2

Caster



5

x2

Caster with Brake

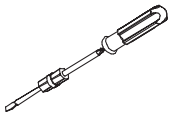

6

x1

Phillips head screw Driver

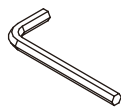

7

x1

Allen Wrench



8

x1

Wrench

HELPFUL HINTS

- Separate parts before starting

STEP 1

Attach Side Frame (E) to Base (D) with Phillips Screw (1). Fully tighten.

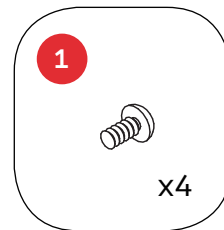
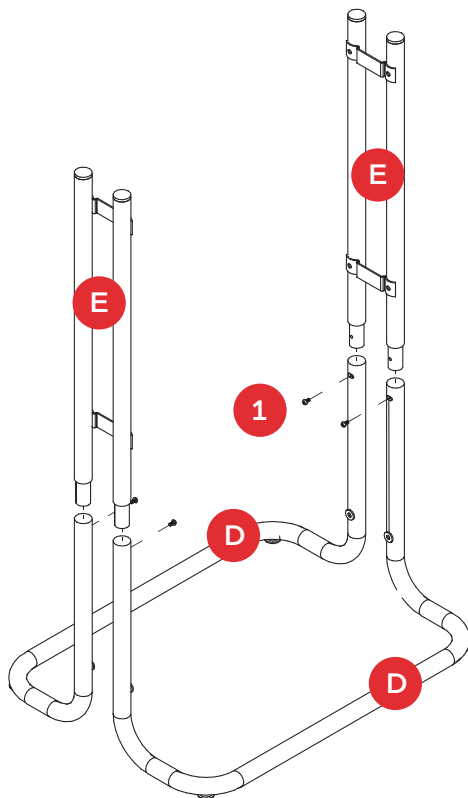

Assembled View:

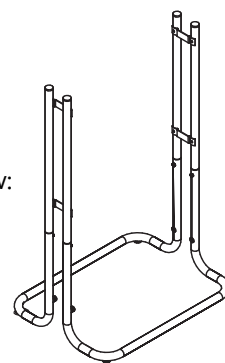

STEP 2

Install the Nut (3) to Caster (4) and Caster with Brake (5).

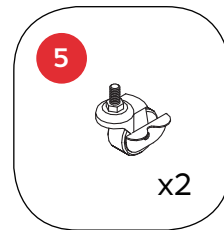
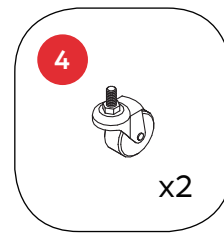
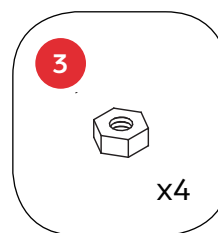
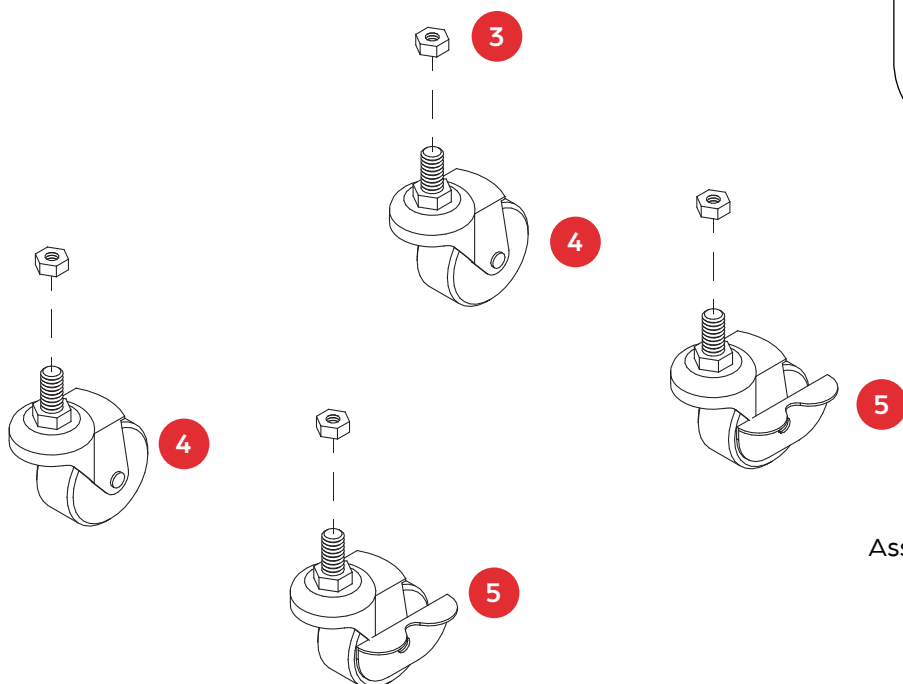

Assembled View:

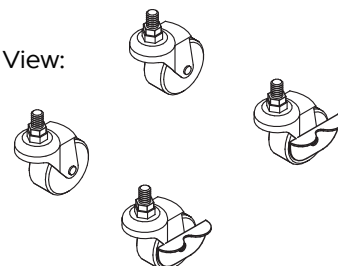

STEP 3

Insert Caster (4) and Caster with Brake (5) assembled in Step 2 into Base (D). Fully tighten.

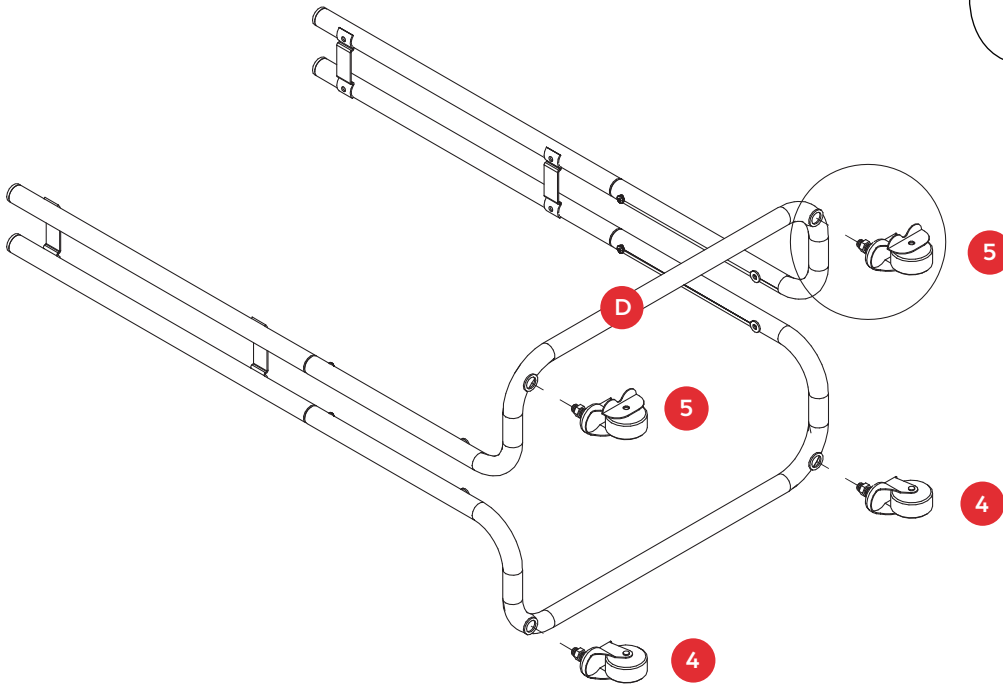
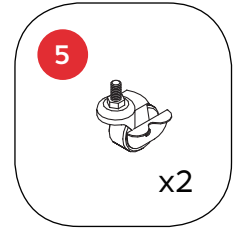
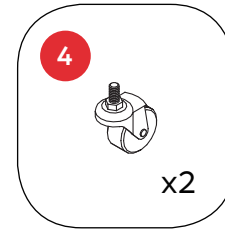

Assembled View:

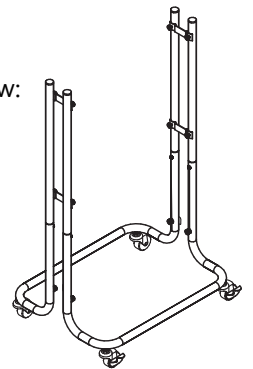

STEP 4

Attach Bottom Basket (C), Middle Basket (B) and Upper Basket (A) to the frame assembled in Step 3 with Allen Bolt (2). Fully tighten. Assembly is now complete.

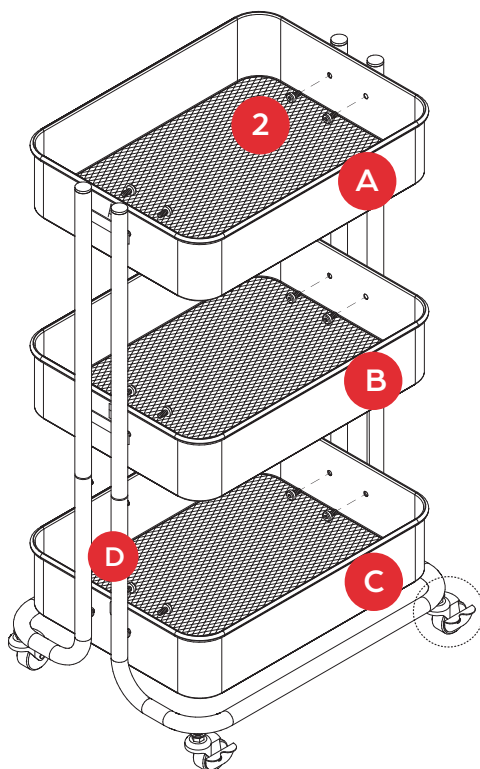

Tips:
If the ground is uneven, you can adjust the gap between the Nut and the Caster to level the Rolling Cart.

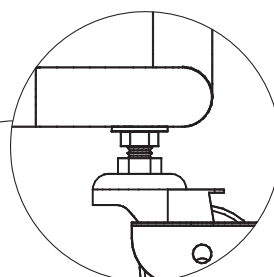

Assembled View:

